

# **Mincing and mealing: a test of offal management strategies to reduce interactions between seabirds and trawl vessels**

Edward Abraham

*Dragonfly, 10 Milne Terrace, Island Bay, Wellington (edward@dragonfly.co.nz)*

Advisory Group:

John Cleal

*F. V. Management Services, P.O. Box 1279, Nelson, New Zealand*

David Middleton

*New Zealand Seafood Industry Council, Private Bag 24-901, Wellington, New Zealand*

Johanna Pierre

*Department of Conservation, PO Box 10-420, Wellington 6043, New Zealand*

Nathan Walker

*WWF-New Zealand, PO Box 6237, Wellington 6003, New Zealand (present address: Ministry of Fisheries, PO Box 1020, Wellington 6001, New Zealand)*

Susan Waugh

*Ministry of Fisheries, PO Box 1020, Wellington 6001, New Zealand*

Report prepared for the Department of Conservation, 7 May 2007 (Update 7 April, 2008).

# 1. Summary

Recent work aimed at reducing the capture of seabirds on trawl warps has shown that warp strikes are associated with the discharge of waste while fishing. Offal management is therefore a key measure for reducing this incidental catch. An experiment to test the effect of two offal management strategies on the numbers of seabirds attending a fishing trawler was carried out during September - October, 2006. The two treatments were (1) sending all offal and waste to the meal plant, so that discharge was reduced to sump water, and (2) passing all waste through a mincer, with 25mm holes in the mincing plate, before discharging it. The two treatments were compared with a control, where all waste was directly discharged. To determine the response to the treatments, bird numbers were counted in a semicircular sweep of 40m radius, centered on the middle of the stern of the vessel and extending behind it. Birds were counted in five species groups (large albatross, small albatross, giant petrel, shearwaters and others, cape petrels) and three behavioural categories (flying, sitting and feeding). The trial covered 21 days, with 7 days of each of the two treatments and the control. During the experiment the vessel fished for hoki off the east coast of the South Island, and also on the Stewart Snares shelf. The mincing treatment did not significantly the numbers of birds within the count area, with the exception of feeding large albatross (*Diomedea spp.*). When the waste was mealed, numbers of feeding birds reduced markedly. The effect was most pronounced for the smaller albatross (*Thalassarche spp.*). Within this group, the numbers of feeding birds reduced to 5.3% of the number that were present when unprocessed waste was being discharged. A small number of seabird strike observations were made on the voyage. The vessel was using tori lines, and there were few warp strikes. The raw data suggested that strikes on the tori lines were reduced during each of the experimental treatments, however modeling suggests that this result is only significant for albatross during the mealed treatment.

## 2. Introduction

Seabirds are attracted to fishing vessels by the availability of food, including discharged waste. If the discharge occurs while the vessel is trawling, then the birds may be struck by trawl warps (Wienecke and Robertson; Abraham, 2005; Abraham et al, 2007; Sullivan et al, 2006a, 2006b). Observations of seabird warp strike have shown that the presence of offal or other discharges is a key risk factor associated with the occurrence of strikes (Sullivan et al, 2006b; Abraham et al, 2007). The challenge is to find methods that will either reduce the discharge while fishing, reduce the attractiveness or availability of the discharge to the birds, or that keep the discharge away from the danger zone between the stern of the vessel and the trawl warps.

As a step towards addressing this problem within New Zealand trawl fisheries, a study was made that compared two offal management treatments. In one treatment, all factory waste was put through a meal plant and converted into fish meal. The only discharges were of sump water. In a second treatment, all factory waste was forced through an industrial mincer before being discharged. The largest pieces in the minced offal were of a fingernail size. These two treatments were compared with a control where all waste was discharged without further processing.

In southern New Zealand trawl fisheries the species which are most often reported caught on the warps are albatross, especially the white capped albatross (*Thalassarche steadi*) (Baird, 2004a, 2004b, 2005; Abraham et al, 2007). As these birds have a large bill, it was anticipated that they would preferentially feed on larger chunks of offal. The mincing was expected to make the discharge less available to these birds.

The key measure used to compare the treatments was a count of birds within a semicircle of 40m radius, centered on the middle of the stern, and extending behind the vessel. Bird counts are closely associated with the occurrence of interactions such as warp strikes (Abraham et al, 2007), and so the bird counts were made as a proxy for the strikes. The numbers of warp strikes themselves were not expected to be a reliable measure during this experiment, as the vessel was using tori lines and so few strikes were expected (Sullivan et al, 2006; Abraham et al, 2007). Counts were also made when the vessel was not fishing, allowing more data to be collected than would have otherwise been possible.

### 3. Methods

#### Experimental design

A single vessel was used to trial the effectiveness of the mincing during a trip that was targeting hoki (*Macruronus novaezelandiae*). The vessel was a Norwegian built trawler (length 71.5 m, beam 16 m, draught 7 m, built 2003), set up for fillet processing. The vessel has a meal plant which is capable of processing all factory waste and bycatch. A mincer (Napier engineering, model PB3-GC) was installed in the vessel's factory. This mincer was designed for use in meat works, and can process several tonnes per hour. The same machines have been used on other fishing vessels to break up offal before going into the meal plant. The mincing plate had 25mm holes, and reduced all waste to a fingernail size or less.

The following three experimental treatments were used:

- Unprocessed. The discharge of all offal and waste from the stern of the vessel
- Minced. The discharge of offal and waste through the mincer
- Mealed. All factory discharge was converted to fish meal, and the only discharge was of water and scraps from the factory sump pump

Each treatment was used for a whole day (from 6 a.m. until 6 p.m.) following a randomized order that had been determined before the trip started. A randomized block design was used, with each treatment being used once within each group of three days. A total of 21 days of observations were scheduled.

Counts were made of five separate species groups:

- Large albatross (royal and wandering albatross; *Diomedea spp.*)
- Small albatross (other albatross; *Thalassarche spp.* and *Phoebetria spp.*)
- Giant petrels (*Macronectes spp.*)
- Shearwaters and other petrels (other *Procellariidae*)
- Cape petrels (*Daption capense*)

The birds were also grouped by their behaviour into three categories:

- flying or gliding
- sitting on the water, but not feeding
- feeding or engaged in feeding related activity including diving, surfacing or aggressive interactions with other birds

The observer carried out counts of each species grouping and each behaviour category separately. To make each count, a single visual sweep count was made through the area. The observer was instructed to spend no more than one minute on each count, a total of no more than 15 minutes per observation. Because each species-behaviour category was

counted separately, some individual birds may have been counted more than once, if they changed behaviour between counts. Similarly, some birds within the area may not have been counted.

The observer also recorded the rate of discharge in four categories:

- sump water
- minced material – material that had gone through the mincer
- offal – heads and guts of processed product
- discards – whole fish, squid or other bycatch

For each discharge type, the observer recorded whether there was no discharge, or whether the discharge was negligible, intermittent, or continuous. The position of each discharge type was also recorded on a diagram of the count area (Figure 1).

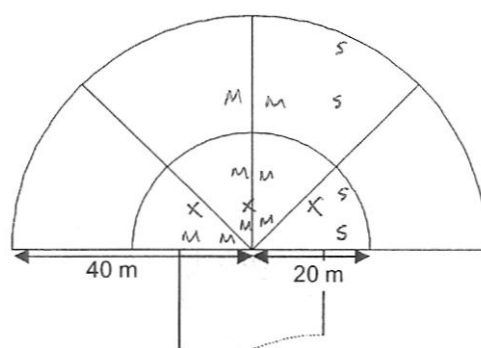

**Figure 1** An example of a completed discharge diagram, showing the 40m radius sweep area behind the vessel stern in which the bird counts were made. The positions of the different types of discharge (in this case minced offal and sump water) are marked by the letters (S = Sump, M = Minced). The positions of the warp entry points are marked by X's.

As part of the experiment a security video system was used to continuously record the activity behind the stern. This footage is not analysed here. The observer also took footage with a hand held video camera, to help interpret the results. Other ancillary data included a log of the quantity of waste produced by the vessel, and station data collected as part of the observer's other duties.

If the vessel was fishing then the observer also recorded warp strikes, following the protocol outlined in Abraham, 2005. The observer watched either a warp or a tori line for 15 minutes, recording the number of heavy contacts made by either albatross and giant petrel, or by other birds. A heavy contact was defined as one where the bird was deflected from its path and the contact was on the head or body, or above the carpal joint (the wrist) on the wing. Discharges and weather and swell conditions were also recorded as part of these warp strike counts. When warp strike counts were made, they were carried out as part of a set of four observations, in the following order:

- Seabird counts
- Counts of strikes on one of the warps (15 minutes)
- Counts of strikes on one of the tori lines (15 minutes)
- Seabird counts

If the vessel was not fishing, then two repeats of the seabird count observations were made.

## **Daily counts**

As part of their regular duties, fisheries observers carry out a regular daily count of birds within 50m of the stern. Birds are counted in ones, tens, hundreds or thousands, and a separate count is given for each clearly identifiable species. These daily counts give information on the make up of each of the groups defined by the experimental protocol.

## **Data entry**

The bird count data were entered into a database. With the exception of the comments, all data were entered by two different people. There were 8 differences between fields entered by the two people, a rate of less than 0.2%, and these were reconciled by comparison with the original forms. Comments on the forms were entered by one person, and then proof read by the other. They were entered verbatim, with the exception of correcting some minor spelling errors. The observer drew some sketches in the comments field. These generally showed the flight paths of the birds, relative to the vessel. Where the sketches included wind information, the wind speed and direction were recorded, otherwise the diagrams were not captured.

The discharge map on each form was scanned and then digitized, with the position of each symbol marked on the diagram being captured from mouse clicks. The raw pixel based positions were transformed into distances from the vessel stern, and from the vessel centerline, based on the axes drawn on the diagram.

An extract of station data for this trip was obtained from the Ministry of Fisheries observer database. These data give information on each tow that was carried out by the vessel. The starting latitude and longitude of the tow and the target species were appended to each bird count observation.

Data on the amount of waste produced by the factory on each experimental day was recorded by the observer. This data was entered into a spreadsheet and merged with the observation data.

## **Statistical modeling**

Raw data was summarised and cleaned. A statistical model was built for each of the 15 species-behaviour groupings to determine whether the treatments were having a significant effect. The count data was assumed to be derived from the negative-binomial distribution (e.g. Venables and Ripley 2002), with the means varying according to the treatments and other covariates.

To select potential covariates, negative binomial generalised linear models were built, using an automated step procedure to select the significant covariates. In addition to the experimental treatments, the potential covariates included wind speed (Beaufort scale),

time of day (hours), whether or not the vessel was fishing, the tonnage of offal discharged during each day, vessel speed (knots), the day of the experiment, and a factor indicating the location of the vessel (East or South fishing ground, see Figure 1). Wind speed was not always available at the time of the observation, as it was only recorded during warp-strike observations, and the closest available wind speed estimate was then used. The factors relating to treatment, whether the vessel was fishing, and the fishing ground were retained in each model, as there were a priori reasons to expect these factors to be important. The step procedure chose between the remaining covariates, using the Akaike information criterion to distinguish between alternate models. Having found a parsimonious model for each series of species-behaviour data an additional selection step was carried out. For each species grouping, covariates were retained that were significant ( $p < 0.05$ ) in two or more of the three behavioural categories. This meant that, within each species group, the three models had the same structure.

After this initial exploration, the selected covariates were used to build final generalised linear models, using Bayesian methods (e.g. Gelman et al. 2003, Congdon 2003). Markov-chain Monte-Carlo methods were used to estimate the model parameters from the data, with the software OpenBugs being used (version 2.2.0 beta, Thomas et al. 2006) from within the statistical software R (version 2.4.0, R Development Core Team 2006). The bird-count observations,  $y_{ij}$  (where the indices represent an individual observation  $i$  from experimental block  $j$ ), were assumed to be drawn from negative binomial distributions with mean  $\mu_{ij}$  and variance  $\mu_{ij} + \mu_{ij}^2 / \theta$ , where  $\theta$  parameterises the overdispersion. The mean value was assumed to be a function of the fixed effects,  $x_k$ , with

$$\log(\mu_{ij}) = \alpha_j + \sum_k \beta_k x_{ik} .$$

Block-level random effects,  $\alpha_j$ , were included in the final model, with a different value for each of the experimental blocks of three days. The values were drawn from a normal distribution, with the standard deviation varying between the different blocks, and with the mean being the intercept of the linear predictor

$$\alpha_j \sim \text{Normal}(\beta_0, \sigma^2) .$$

The inclusion of the intercept ( $\beta_0$ ) within the random effects distribution was found to improve convergence in the model. If the intercept was included as a fixed effect, there was a correlation between the intercept and the random effects, and the estimated intercept was liable to wander. Covariates which had the same value throughout an experimental block, such as the fishing ground, were not included in the model, as they could be accounted for by the random effect.

Given the mean and the overdispersion, the observations are compared with samples from a Poisson with a Gamma-distributed mean, which generates the appropriate negative binomial distribution,

$$\delta_{ij} \sim \text{Gamma}(\theta, \theta / \mu_{ij}) ,$$

$$y_{ij} \sim \text{Poisson}(\delta_{ij}) .$$

To complete the model specification, priors are required for the parameters  $\beta_k$ , and hyperpriors for the hyperparameters  $\beta_0$ ,  $\theta$  and  $\sigma$ . We chose the vague bounded uniform (hyper)priors below for all these (hyper)parameters.

$$\beta_k \sim \text{Uniform}(-10,10)$$

$$\beta_0 \sim \text{Uniform}(-10,10)$$

$$\log(\theta) \sim \text{Uniform}(-3,5)$$

$$\sigma \sim \text{Uniform}(0,10)$$

The bounds were chosen on the assumption that higher or lower values of these parameters would be unreasonable. Parameters that approached these bounds might suggest problems with model mis-specification. On some treatments and in some behavioural categories there were no birds observed, and the lower bound prevents the corresponding treatment effects from drifting towards negative infinity. The choice of a uniform prior for the standard deviation of the random effects follows the recommendations of Gelman (2006).

For each model fit, two chains were run. The chains were initialised with values derived from a similar generalised linear model that was fitted in R. For all the final model runs reported here, the simulations were run for an initial burn-in period of 100,000 iterations. After discarding the burn-in, 5000 samples were retained from each chain, with a thinning interval of 500 updates. The large thinning interval was needed as some covariates were highly autocorrelated. The median of the posterior of each parameter was used as the best estimate, and credible intervals were determined from the 2.5% and 97.5% percentiles of the posterior distributions. Convergence was determined from inspection of the posterior densities, and of traces of the chains. More formally, a diagnostic based on a Cramer-von-Mises test of whether the sampled values come from a stationary distribution (Heidelberger and Welch 1983) was used to determine whether the chains of parameters associated with the treatment effects had converged.

To ascertain whether the experimental discharge treatments had a statistically significant effect on tori line strikes, two generalised linear models of the warp strikes were built, following the methodology given above. In the first, the only factors that are included are the treatment effects, and in the second the bird counts are also included. Because of the low numbers of observations, we are unable to explore whether other covariates have a confounding effect.



## 4. Results

### Observation data cleaning

Form numbers were written by the observer. In general these were sequential, however form numbers 36, 37 and 38 were allocated twice. Before data entry, one of each the duplicates were shifted to the end (and given the respective numbers 163, 164 and 165). There was no form number 140.

There were a small number of data issues (Table 1). Some of these refer to interpretations made of the forms, and others indicate that the observation may not be valid. As a consequence, form numbers 4, 11 and 80 were dropped from further analysis. Of the 164 forms completed by the observer, 161 were accepted as valid observations.

**Table 1 Issues encountered during the data entry**

Form number	Issue	Action
4	Offal discharge stopped during sweep counts and the bird behaviour changed	Observation discarded
11	Vessel turned during the sweep counts	Observation discarded
55	It was unclear whether mince could be seen or not, mince discharge recorded on form as "?1"	Entered into database as "1"
80	The meal plant blocked, and there was discharge of whole fish heads	Observation discarded, as this was a meal treatment
86	Time was written into the tow number field. Checking the observer station data, this observation was not during a tow	No tow number was entered
98	The number of "Shearwaters sitting" was recorded on the form as "-"	Entered as "0"
143	There was no recorded observation of cape petrels feeding	Entered as a null value
145	From the form sequence it is clear that the date was entered incorrectly on this form.	The date was corrected.
153	Comments were made about where the birds were feeding that did not appear to match the numbers	No action

Environmental data (wind speed and direction and swell height and direction) from the seabird strike forms was used to estimate the wind and swell data at the time of the bird count observations. For each count observation, the wind and swell data was copied from the closest warp strike observation, provided that it was within 12 hours. Unfortunately, there were days when bird counts were made, but not warp strike observations, so the wind and swell data had missing values.

## Seabird strike data cleaning

Warp or tori line strike observations were made during 36 tows, with a total of 109 observations. There was some missing information on the forms which was inferred. In particular, there were 25 observations where it was not recorded whether the trawl warps or the mitigation devices were observed. These were completed on the assumption that the protocol had been followed, with a sequence of warp strike observations alternating between observations of the warps and the mitigation device, with the trawl warps being observed first.

There were four observations with missing discharge rate data (23/1, 33/1, 34/3 and 37/3), where the numbers refer to the form number and the sample number, respectively. In the latter three cases the discharge rate could be inferred on the assumption that it was the same as the rate seen on bracketing observations. Similarly, the wind direction was inferred on one observation (65/3).

A number of bird strike observations were removed. In the comments below, the numbers refer to the station and sample numbers of each observation.

- One observation (65/4) was removed because it recorded the trawl warp as being observed, even though the protocol expected the mitigation device to have been observed. This appears to have been a mistake, but because it is not clear, the observation was discarded.
- Two observations (26/1 and 56/4) were removed because the observation time was less than the required 15 minute interval. Comments indicated that during these observations the vessel became stuck and began to haul the gear, so the observations had been abandoned.
- One observation (49/2) was discarded because the interval was longer than the required 15 minute interval, and heavy contacts were recorded. Another long observation was retained as no contacts were observed, implying no contacts during the correct 15 minute interval.
- A further observation (50/4) was removed because the bird contact data was not entered.

Following this grooming, a number of observations were flagged as having unusual discharge rates or types. These were removed to allow a clear effect of the differing experimental treatments to be determined.

- The observation with missing discharge rate information (23/1) was removed
- There were five observations with either negligible or no discharge (25/1, 25/2, 27/2, 45/1, 45/2). Because the aim is to compare treatment effects, rather than the effect of variations in the discharged amount, these observations were removed.
- Three observations (12/1, 12/2, 60/1) were removed that recorded the discarding of offal during a minced treatment.

This left a total of 96 individual observations from 31 different tows. When broken down into the different treatments and between the warps and the mitigation devices (Table 2), the number of observations is small (20 or less).

**Table 2 Final number of warp strike observations, by treatment.**

Treatment	Tori line observations	Warp observations
Unprocessed	17	20
Minced	11	14
Mealed	15	19

## Data synopsis

### The voyage

Observations were made between September 18 and October 10, 2006. All the observed tows were within two distinct areas (Figure 2). The voyage began on the Canterbury shelf and then moved to the Stewart Snares shelf on October 2. The southern observations spanned two fisheries management areas (SOU and SUB). There were 110 observations in the East group, and 51 observations in the South group.

Observations were made on every day from the start of the experiment, with the exception of 22 September, when the vessel returned to Lyttleton for repairs, and 2 October, when the vessel was moving between the fishing grounds.

### Start time

The start time of the bird count observations is shown in Figure 3. The protocol required observations to be carried out between 6 am and 6 pm. Apart from a peak between 6 and 7 in the morning and a small number of observations made between 5 and 6 in the evening, there was an even coverage of effort through the day.

### Vessel speed

Observations were made both when the vessel was fishing and between tows. There were 55 observations (34%) made when the vessel was towing. The trawl warps were marked on the discharge diagram on 30 of these observations. A binary factor was introduced which indicated whether or not the vessel was fishing during the observation.

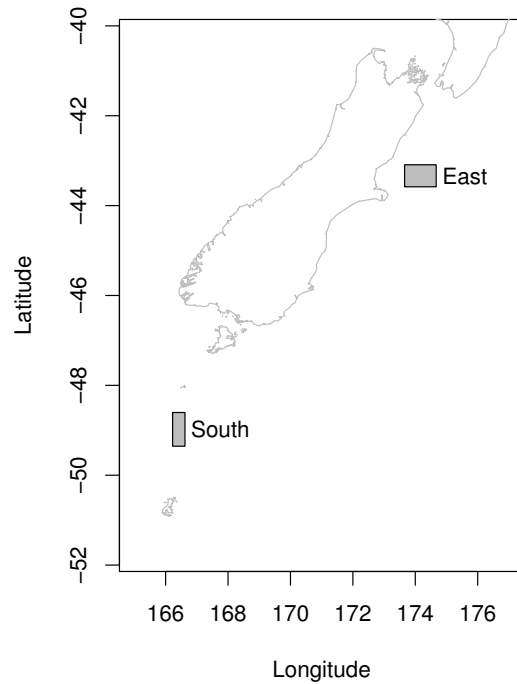

**Figure 2** Positions of the bird count observations. The observations were concentrated in two distinct areas, one on the Stewart- Snares shelf (“South”) and one on the Canterbury shelf (“East”). The trip began on the Canterbury shelf and then moved south on October 2.

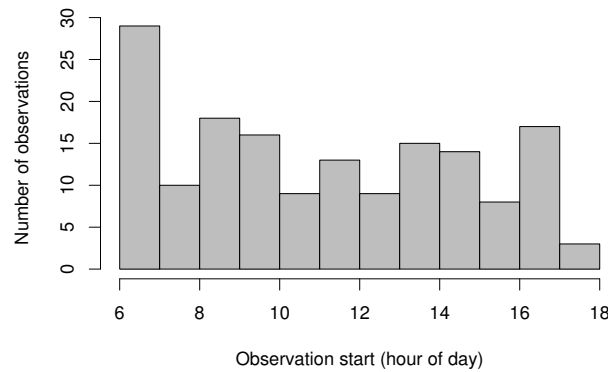

**Figure 3** Distribution of observation times through the day.

Vessel speeds are shown in Figure 4. When towing, the minimum vessel speed recorded was 3.8 knots and the maximum speed was 5.7 knots. At other times the speed varied from close to stationary to over 10 knots. We defined fishing speeds to be between 3.5 and 6 knots. There are 12 observations (8%) at slower than fishing speeds, 121 (75%) at typical fishing speeds, and 21 (17%) at speeds which are faster than typical fishing speeds. The modeling of the bird count observations was restricted to observations which were made when the vessel was at a fishing speed. This is to avoid including observations made under situations which would be atypical for a vessel when it was trawling.

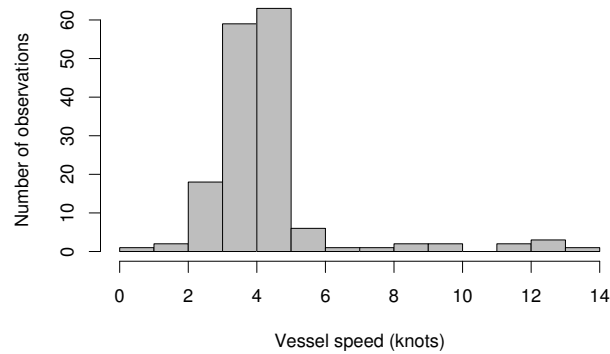

Figure 4 Distribution of vessel speed across all observations.

## Experimental schedule

An experimental schedule was generated before the voyage that listed a random sequence of treatments. The prepared schedule was followed exactly (Table 3). However, the number of observations made during a day varied between a minimum of three and a maximum of 11. The observer found that the observations were difficult or unsafe to make in rough weather and the main reason for low numbers of observations during a day was the poor conditions.

Table 3 The number of observations made during each day of the experiment

Date	Treatment	Count Observations	Strike observations
18/09/2006	Unprocessed	10	0
19/09/2006	Mealed	11	0
20/09/2006	Minced	7	0
21/09/2006	Mealed	10	4
23/09/2006	Minced	10	5
24/09/2006	Unprocessed	7	2
25/09/2006	Minced	7	1
26/09/2006	Unprocessed	11	4
27/09/2006	Mealed	9	3
28/09/2006	Minced	7	8
29/09/2006	Mealed	9	10
30/09/2006	Unprocessed	9	2
1/10/2006	Mealed	3	6
3/10/2006	Unprocessed	4	8
4/10/2006	Minced	7	4
5/10/2006	Unprocessed	7	10
6/10/2006	Mealed	8	7
7/10/2006	Minced	6	7
8/10/2006	Mealed	4	4
9/10/2006	Unprocessed	6	11
10/10/2006	Minced	9	0

## Offal discharge

The occurrence of different offal discharges is shown in Table 4 for the three different treatments. Sump water is discharged at the same rate on nearly all observations (there is only a single exception), irrespective of the treatment. During the unprocessed treatment, the other discharge is primarily of offal, with the exception of four observations where some discards were observed. Most observations during the minced treatment recorded a continuous discharge of minced waste. Similarly, during the mealed treatment there was no recorded discharge of anything other than sump water (there was a single exception, when the meal plant became blocked, however this observation was removed during the initial cleaning).

The three treatments have clearly different discharge characteristics. There are some exceptions. When looking for treatment specific differences in bird numbers, we want the discharge rates to be typical for the treatment. In particular, we exclude observations where the discharge rate is low, in case these skew the results. We select the observations according to the following criteria.

- Sump discharge at least “Intermittent” (excludes one observation)
- Treatment is “Unprocessed” and discharge of offal is at least “Intermittent” (excludes 10 observations)
- Treatment is “Minced” and discharge of minced offal is “Continuous” (excludes three observations)

There were few records of discards being discharged, but they always occurred together with offal and so we retained them in the dataset. In the final data set there were 54 observations with unprocessed discharge, 53 with minced offal and 54 with all factory waste being mealed, and so only sump discharge.

**Table 4 Numbers of observations, grouped by discharge type and discharge rate, for the three different treatments. The observations that were excluded from the modeling are indicated by the shaded cells.**

		Discharge rate			
		None	Negligible	Intermittent	Continuous
Unprocessed					
Sump		1	0	53	0
Minced		54	0	0	0
Offal		8	2	16	28
Discards		50	1	3	0
Minced					
Sump		0	0	53	0
Minced		1	2	0	50
Offal		53	0	0	0
Discards		53	0	0	0
Mealed					
Sump		0	0	54	0
Minced		54	0	0	0
Offal		54	0	0	0
Discards		54	0	0	0

Initially, a pipe for discharge was attached at the side of the vessel with the intention that the minced offal would be discharged below the waterline. This pipe broke off shortly after the voyage began. For the first day of the minced treatment, 20 September, the minced offal was discharged from the pipe onto the surface of the water at the side of the vessel. After the first day, the minced discharge was directed through the wave gate, appearing at the stern of the vessel in the prop wash. The unprocessed offal was also discharged directly behind the vessel.

There were some problems with the minced offal binding together and entering the water as clumps, which were attractive to the birds. The clumping of the mince depended on what was being processed, and was partly solved by discharging the minced offal into the propeller wash, where the strong water motion broke the clumps apart. Most comments which mention the binding of the offal (Appendix A) are from the first few days of the trial when the weather was calm. Viewing of video from early in the experiment shows visible chunks in the water which are being chased and pecked at by the small albatross.

## Offal map

The positions of the offal discharge are shown in Figure 6. This figure shows data from all observations that meet the criteria discussed above. The sump discharge is present in all three treatments and on both sides of the vessel. It continues in two clear lines behind the side of the vessel, and remains outside the position of the trawl warps. Immediately aft of the vessel, both the mince and the offal discharge are concentrated on the starboard side. The mince spreads across the centerline, and stays visible for longer than the offal. There is more mince recorded between 30m to 40m than there is offal.

When the vessel was fishing, the observer marked the position of the trawl warps on the offal diagram. The difference in the mean positions of the left and right warp was 20m. As the beam of the vessel was only 16m, and the warps enter the water somewhat inside the sides of the vessel, it is clear that the observer has not plotted the diagram to scale. Unfortunately, the diagram printed on the form included a vessel stern (Figure 1). If drawn to scale, this stern would be 25m across. It appears that the observer has used the stern printed on the diagram as a guide, rather than the meter scale. We will assume that all forms have been completed consistently, but note that quoted distances derived from this diagram will be larger than they actually were. In subsequent printings of this form, the stern has been removed.

A histogram showing the percentage of recorded discharge positions at different distances from the stern is shown in Figure 6. The recorded discharge falls with distance from the stern, and the offal falls away faster than the mince. There is a significant difference between the rates at which the two discharge types fall away. If an exponential decay is fitted using a linear model to the two lines shown in Figure 6, so the proportion falls away as  $\exp(-\alpha x)$ , then for the mince  $\alpha = 0.047$  (95% c.i.:  $0.034 \text{ m}^{-1}$  to  $0.060 \text{ m}^{-1}$ ) and for the offal  $\alpha = 0.10 \text{ m}^{-1}$  (95% c.i.:  $0.067 \text{ m}^{-1}$  to  $0.14 \text{ m}^{-1}$ ). The two discharge types may have different visibilities, and the form was not completed with this level of detailed analysis in mind, so it is not clear that this represents a real difference. Taken at face value, however, it suggests the mince is remaining on the surface for longer than the offal, with a fall off rate of only half the offal rate.

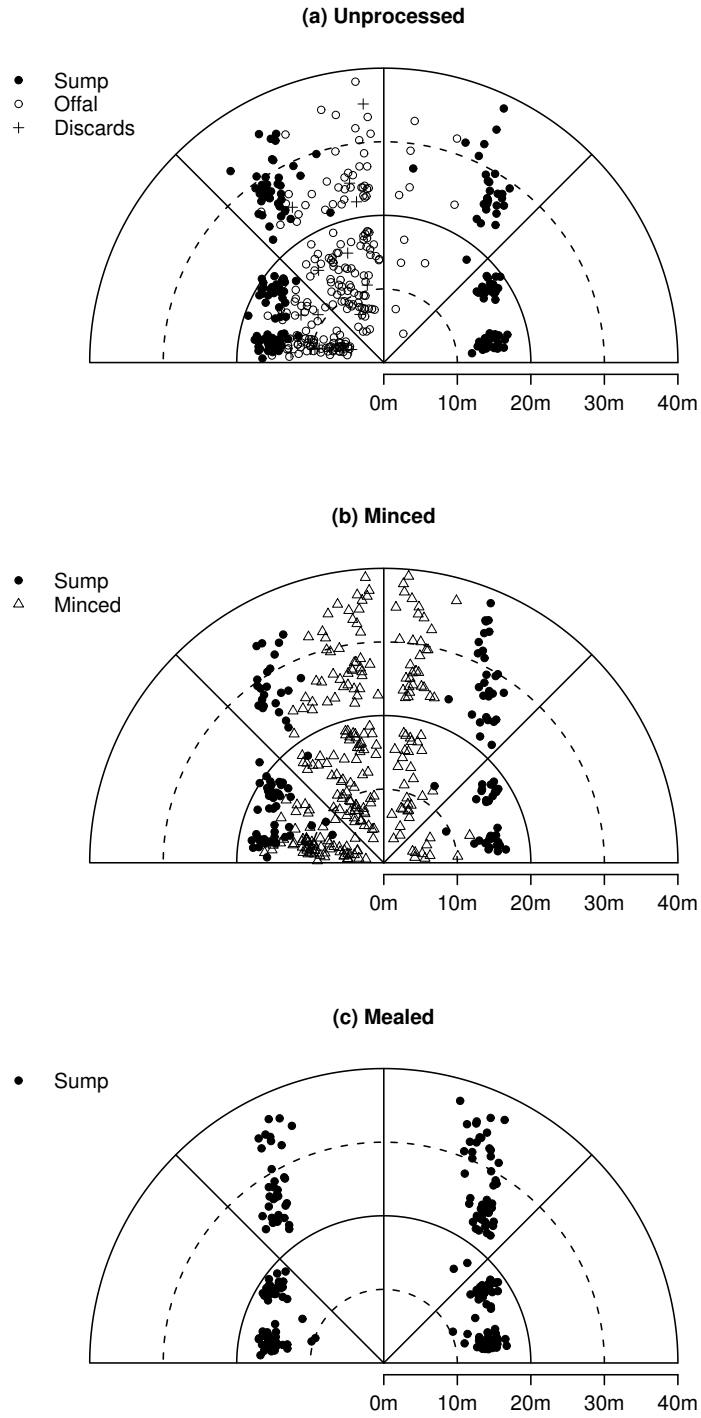

Figure 5 Positions of discharge for each of the three treatments, from all selected observations. Symbols have been jittered by up to 1m in either direction to reduce overlap.



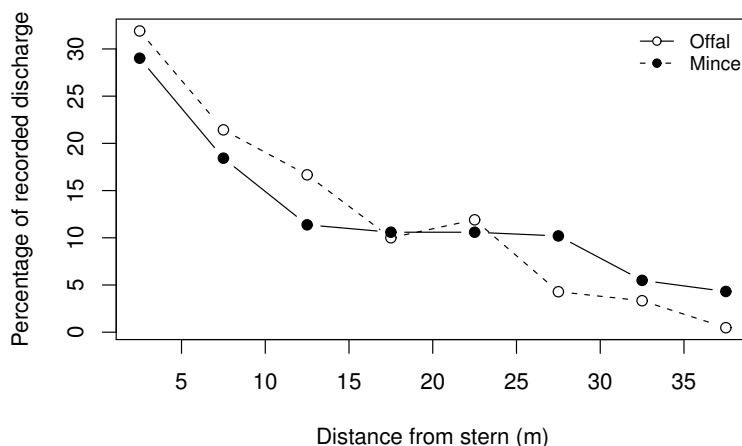

Figure 6 The proportion of recorded discharge as a function of distance from the stern. The data is binned into 5m intervals.

## Daily counts

Data from the daily bird counts are shown in Table 5. The assemblages of birds around the vessel were dominated by the cape petrel, small albatrosses and the other petrel groups. Giant petrels and large albatrosses are present in relatively low numbers. In the eastern region, Salvin's albatross (*Thalassarche salvini*) was the most frequent smaller albatross, whereas in the southern region white-capped albatrosses were more common. The 'other petrel' category was a mix of both sooty shearwaters and white-chinned petrels, and both of these species were largely absent from the eastern region.

Table 5 Median number of birds around the vessel, with range given in brackets, for days during the experiment when the vessel was at the Eastern fishing ground, and when it was at the Southern fishing ground. Birds are identified to the species level where possible. No other species, apart from those listed, were recorded by the observer.

Group	Common name	Scientific name	Mean bird count	
			East	South
Large albatross	Southern royal and wandering albatross	<i>Diomedea epomophora</i> , <i>D. antipodensis</i> , <i>D. exulans</i> , <i>D. gibsoni</i>	11 (3 – 19)	4 (3 – 11)
Small albatross	White-capped albatross	<i>Thalassarche steadi</i>	20 (0 – 30)	200 (150 – 300)
	Black-browed albatross	<i>Thalassarche melanophrys</i>	1 (0 – 1)	50 (20 – 70)
	Salvin's albatross	<i>Thalassarche salvini</i>	300 (100 – 320)	5 (3 – 6)
	Buller's albatross	<i>Thalassarche bulleri</i>	0 (0 – 1)	10 (5 – 20)
Giant petrel	Giant petrel	<i>Macronectes spp.</i>	13 (7 – 22)	30 (20 – 70)
Cape petrel	Cape petrel	<i>Daption capense</i>	600 (400 – 800)	600 (400 – 800)

Other petrel	White-chinned petrel	<i>Procellaria aequinoctialis</i>	10 (0 – 60)	200 (150 – 200)
	Sooty shearwater	<i>Puffinus griseus</i>	30 (0 – 300)	300 (200 – 300)

## Bird counts

The raw bird count data from the experiment is summarized in Figure 7. This shows histograms of the total numbers of birds (the sum of feeding, flying and sitting) within the 40m sweep area, for each of the species categories, for all treatments. Cape petrels are the most numerous, and are present on most tows. Small albatross are also around the vessel on most tows. The distributions for the large albatross, giant petrels and shearwaters are strongly skewed. There are many observations where zero counts for these birds were recorded. The variability is extreme for the shearwaters: they are mostly absent, but on one tow there were close to 500 within the sweep area. The large numbers of zeros in the shearwater data are due to them being absent early in the voyage.

(a) Large albatross

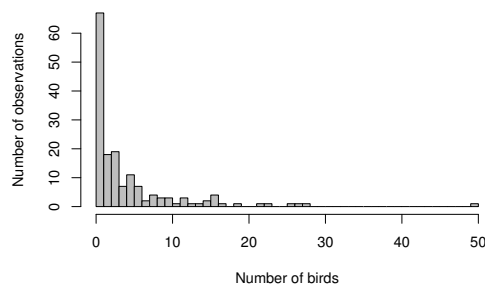

(b) Small albatross

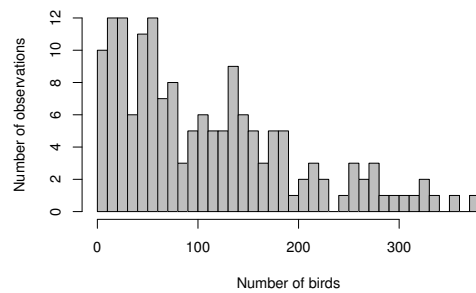

(c) Giant petrel

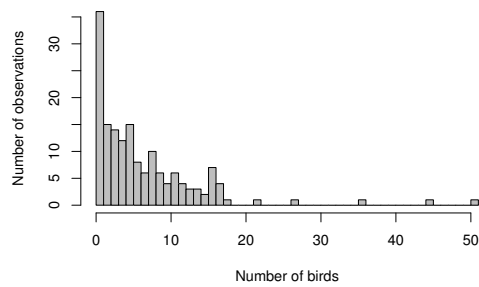

(d) Shearwaters and others

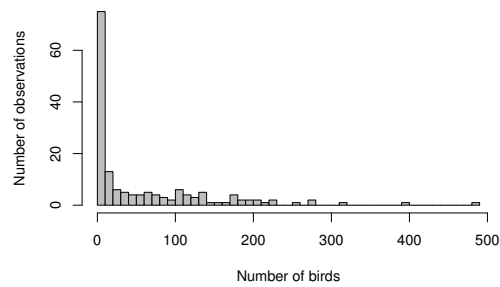

(d) Cape petrel

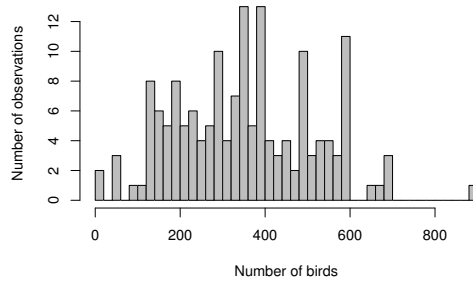

Figure 7 Histograms of the bird count data (the sum of flying, sitting and feeding birds) for each of the species.

**Relation between bird counts and treatments**

The average bird count within each category and treatment is presented in Table 6. Large albatross are the only group where the minced treatment has, on average, a smaller number of feeding birds within the sweep area than the unprocessed treatment. The minced treatment also reduces the number of large albatross sitting or flying within the sweep area.

For all of the bird and behaviour groups (with the exception of flying giant petrel), there are on average less birds within the sweep area when the discharge is being mealed, compared to when it is unprocessed.

Table 6 Mean bird count within each treatment.

	Flying			Sitting			Feeding		
	Unprocessed	Minced	Mealed	Unprocessed	Minced	Mealed	Unprocessed	Minced	Mealed
Large	3.1	1.5	1.1	4.6	1.4	0.8	1.1	0.1	0
Small	48.7	43.8	30.2	67.8	64.1	24.5	26.6	29.2	2.8
Giant	1	1.3	1.1	4.1	4.6	4	1.5	1.8	0.7
Shear	41.8	36.6	19.4	28.6	21.7	11.9	7.2	9.5	1
Cape	115.3	109.4	108.3	181.7	169.8	178.1	74.1	84	58

Histograms showing the distribution of the data are shown in Figure 8. While giving more detail, these show the same result, that the minced treatment was effective at lowering the counts of the large albatross, but did not appear to have an effect in the other categories.

(a) Large albatross

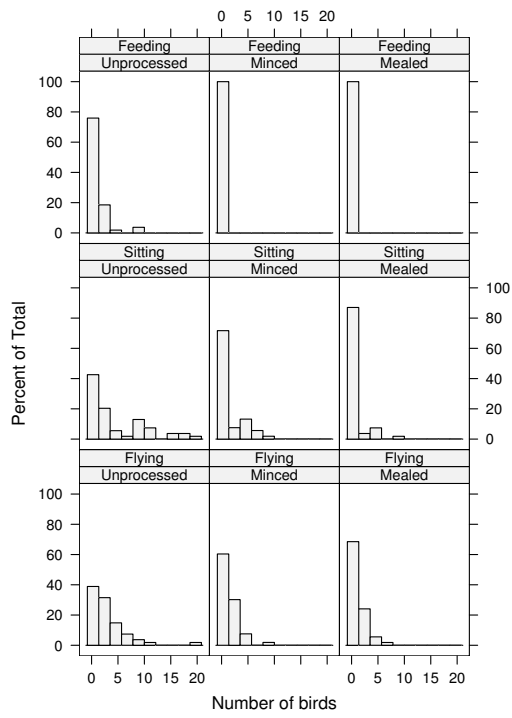

(b) Small albatross

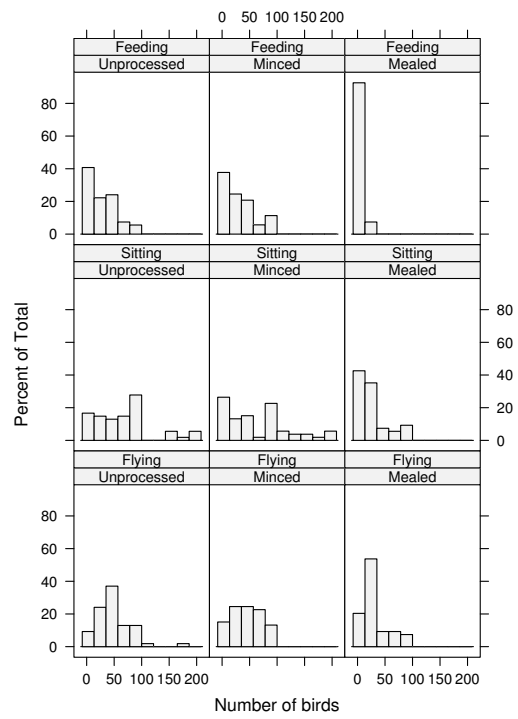

(c) Giant petrel

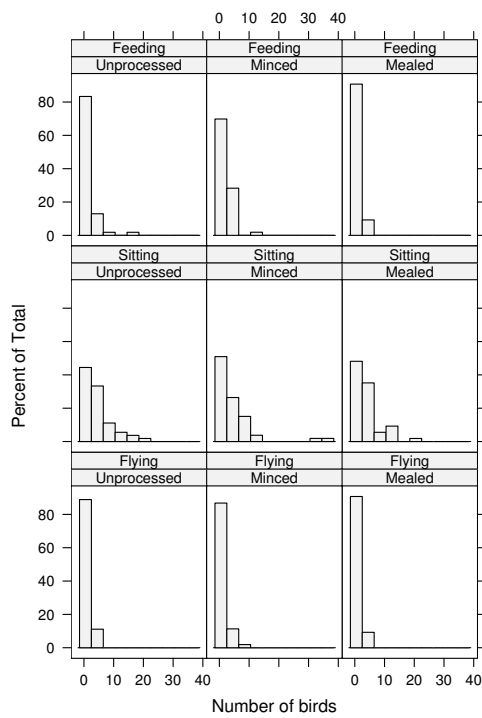

(d) Shearwaters and others

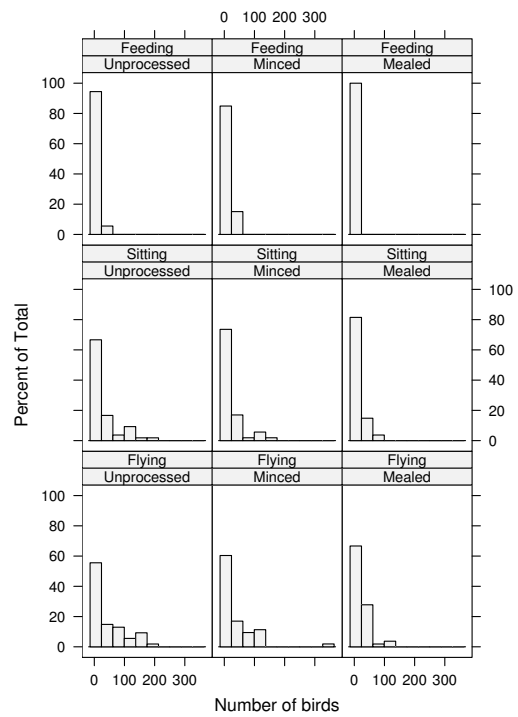

(e) Cape petrel

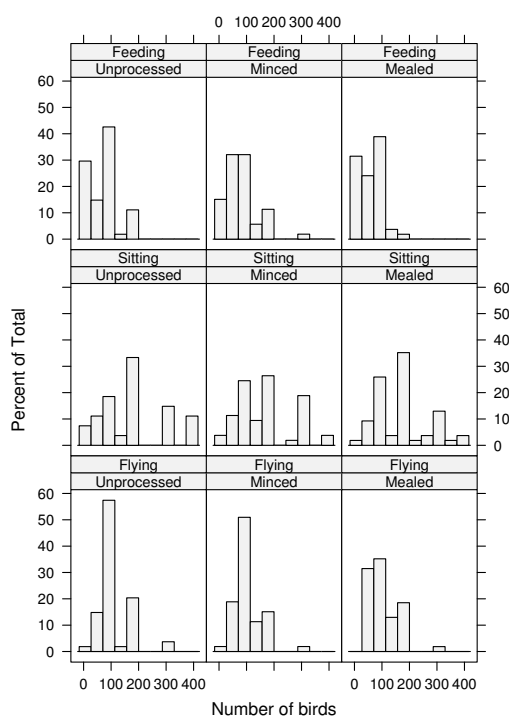

Figure 8 Histograms of the bird count data, by treatment and by behaviour category.

### Time series

Time series of the total bird counts for each species (the sum of the flying, feeding and sitting behavioural categories) are shown in Figure 9. This gives the counts within each of the seven experimental blocks (there were seven blocks, each of three days). The ship moved to the southern fishing ground during the 5<sup>th</sup> experimental block. The shearwaters returned from their annual migration during the experiment, arriving in large numbers during the 4<sup>th</sup> experimental block.

### Strike data

There were a total of 45 albatross contacts on the tori lines across the trial (a mean rate of 1.05 birds per 15 minute observation), and a total of 72 other bird contacts (a mean rate of 1.67 birds per 15 minute observation). In contrast, there were few strikes on the trawl warps (3 large birds and 9 small birds, a rate of 0.06 and 0.17 birds per observation, respectively). Because of the low number of strikes on the trawl warps, we will not look for treatment effects in this data. Rather, we focus on the strikes on the tori lines.

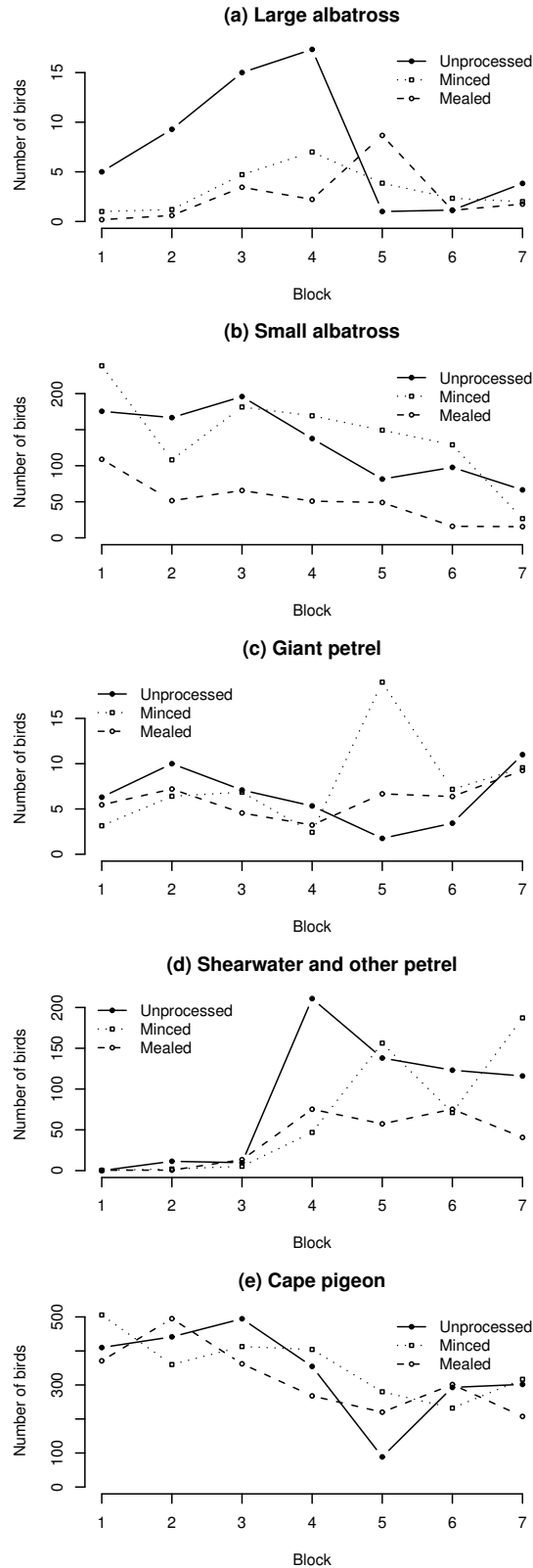
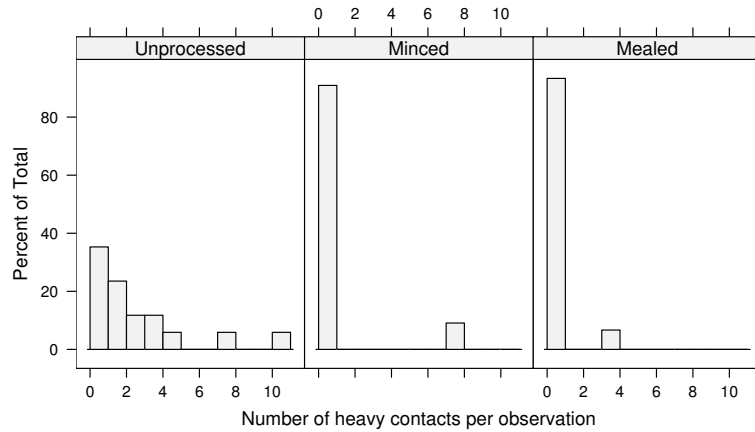

Figure 9 Time series of bird count data, for each of the three treatments. The data is shown for each experimental block of three treatments.

The distribution of heavy contacts on the tori lines is shown in Figure 10. Across all observations, the maximum number of heavy contacts was 10 for the albatross group and 8 for the other birds. For the albatross group, in each of the minced and the mealed

treatments, heavy contacts were only recorded during a single observation period. In contrast albatross heavy contacts are recorded during 11 of the 17 observations (65%) made with the unprocessed treatment. These results suggest that both the minced and the mealed treatment may be effective at reducing the strikes on the tori lines. This conclusion will be investigated using the statistical modeling.

**(a) Albatross strikes**



**(b) Other bird strikes**

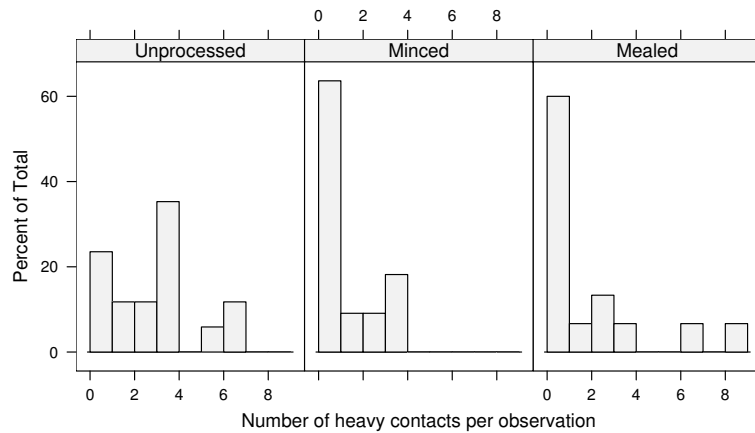

**Figure 10 Heavy contacts of small birds on the tori lines. A comparison of the distributions of the numbers of warp strikes per observation, for the three different treatments.**

**Factory waste**

With the exception of two days, the observer recorded the production of factory waste (offal and whole fish) on each day of the experiment. The waste production ranged from 6.3 tonnes per day to 22.0 tonnes per day, with a mean value of 12.9 tonnes per day. The daily production is shown in Figure 11.

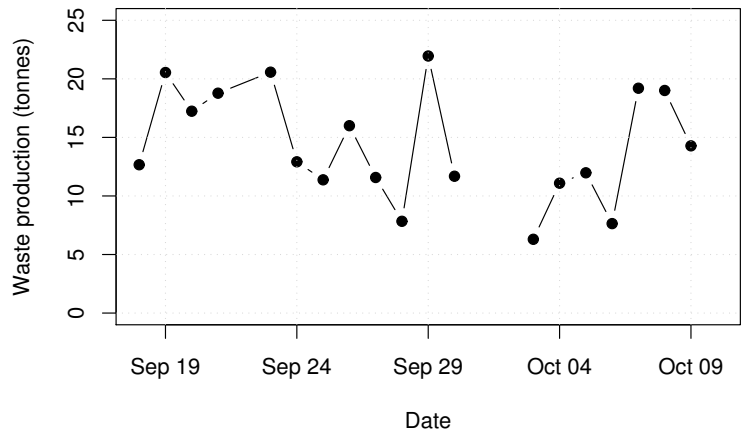

**Figure 11** Daily production of waste (offal and discards) by the factory.

When the daily waste production is grouped by treatment, Figure 12, it appears that the unprocessed treatment happened to be carried out on days when there was generally less waste produced. It should be borne in mind that this is daily data, rather than a direct measure of the amount of waste produced during each observation. We have no estimate of the quantity of waste being produced at the time of each observation, beyond the qualitative assessment of discharge rate.

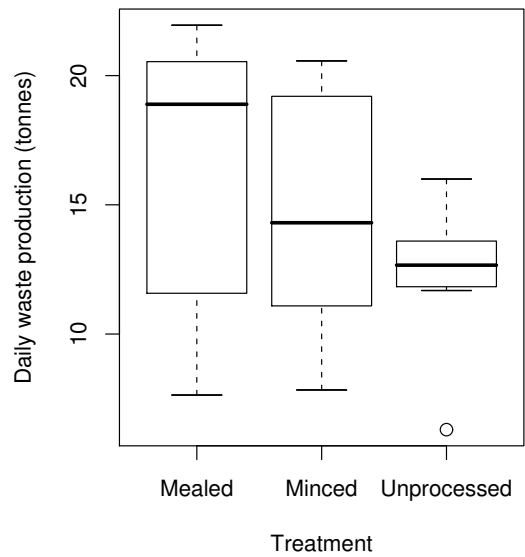

**Figure 12** Production of factory waste (offal and discards) grouped by treatment. The lines mark the median tonnage, with the box given the inter-quartile range, and the whiskers giving the range of the data. Isolated points mark possible outliers.



## Statistical modeling

In all of the Bayesian models the treatment effects and a factor indicating whether the vessel was fishing were included. The only other covariates that were carried through from the initial analysis to the Bayesian modeling were wind speed (for all groups apart from large albatross) and time of day (for small albatross). All model chains passed the stationarity test for the treatment effects, although the diagnostic suggested that three chains had not achieved convergence after the initial burn-in. Given that 60 different chains were tested, we were not concerned by this failure. The model predicted mean counts for each observation are shown in Figure 13. The correspondence between the predicted means and the observations suggests that there are no gross errors in the model. The suitability of the negative binomial model was checked by inspecting the quantile residuals (Dunn and Smyth 1996). Most models have the expected distribution of residuals, with the exception of feeding cape petrel. In this case there are more observations with low numbers of cape petrels than would be expected from the fitted distribution. The only treatment effect which approached the bounds of the prior was the mealed treatment for feeding large albatross. There were no observations in this category.

The results of the statistical modeling are summarised in Figure 14. The mealed treatment had significant effects for all behavioural categories amongst both albatross groups and for the other petrels, with the biggest reductions being in the numbers of feeding birds. When all discharge was mealed, the numbers of feeding small albatrosses and of other petrels were reduced to less than five percent of the numbers counted during the unprocessed treatment. No large albatrosses were observed feeding when the waste was mealed. There were significant reductions in the numbers of large albatrosses under the minced treatment, across all behavioural categories. The reduction was greatest in the feeding large albatross category. This category reduced to less than five percent of the number of large albatross present when unprocessed waste was discharged.

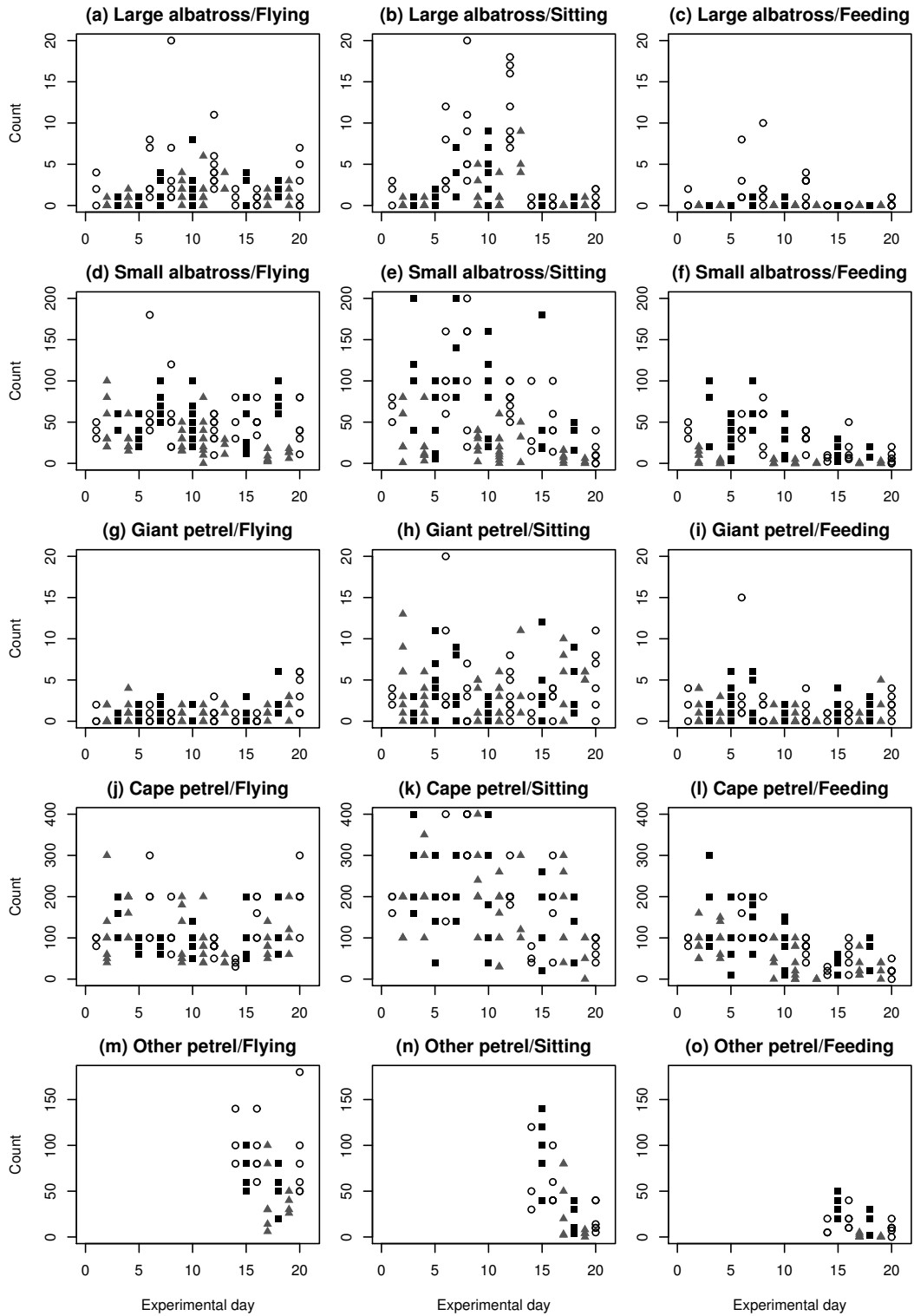

Figure 13 Raw sweep counts for each of the 15 species group and behavioural categories. The different symbols represent the different treatments (○ – Unprocessed, ■ – Minced, ▲ – Mealed).

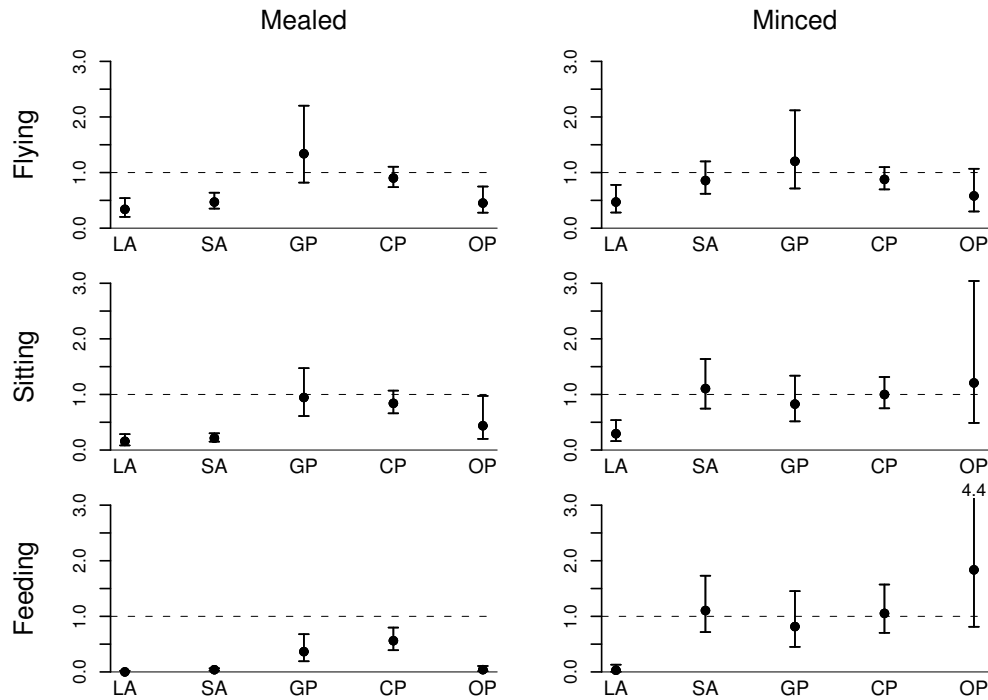

Figure 14 Summary of the treatment effects for the 15 models of the bird counts, by behaviour and species group. The figure shows the median of the posterior distribution and the 95% credible interval for the coefficients of the mincing and mealing treatment effects. The effects are exponentiated, so that they are multiplicative, with no effect having a value of one. The letters indicate the species group (LA = large albatross, SA = small albatross, GP = giant petrel, CP = cape petrel, OP = other petrels). Credible intervals that go above a factor of 3 are truncated, and the upper limit is then indicated by a number.

## Tori line strikes

There were 47 albatross contacts on the tori lines across the trial (a mean rate of 1.07 birds per 15 minute observation), and a total of 77 other bird contacts (a mean rate of 1.75 birds per 15 minute observation). The overall rates of other bird tori line contacts are similar between the East and South fishing grounds (1.81 and 1.69 strikes per observation, respectively). At the time of the experiment, sooty shearwaters and white-chinned petrels were large absent from the eastern region, suggesting that most of these strikes were associated with cape petrel, the only other species in this category that was present in large numbers (Table 5).

Table 7 Mean numbers of tori line strikes per 15 minute observation, for each of the three treatments. The confidence intervals are 95% percentiles from 1000 bootstrap samples of the data. Strike rates that are significantly different from the unprocessed treatment are shown in bold.

	Treatment		
	Unprocessed	Minced	Mealed
Number of observations	17	11	16
Albatross	2.1 (1.1 - 3.2)	0.6 (0 - 1.9)	<b>0.3</b> (0 - 0.7)
Other birds	2.4 (1.6 - 3.1)	<b>0.8</b> (0.3 - 1.4)	1.7 (0.8 - 2.8)
All strikes	4.5 (3.2 - 5.9)	<b>1.4</b> (0.5 - 2.6)	<b>2</b> (0.8 - 3.4)

There were few strikes on the trawl warps (one albatross and four other birds, a rate of 0.02 and 0.08 birds per observation, respectively). Because of the low number of strikes on the warps, we did not look for treatment effects in this dataset. The variation in the numbers of strikes on the tori lines is shown in Table 7. The raw data suggests that the treatments were reducing the numbers of strikes on the tori lines, however the number of strike observations is low. Since strike data can be highly skewed, with large numbers of zeros and occasional observations with high strike numbers (Middleton and Abraham 2007, Abraham et al. 2007), small numbers of observations may lead to poor estimates of the underlying strike rates.

The median values of the posterior distribution produced from the statistical modeling show that for both the mealed and the minced treatments, and for both the albatross and the other bird groupings, the treatments are reducing the numbers of tori line strikes (Table 8). Because of the uncertainties, however, the only effect that is significant, at the 95% credible level, is a reduction in tori line strikes by large birds associated with the mealing treatment. If bird count is introduced into the model, through adding a covariate  $\log(count + 1)$ , then bird count is significant (in the albatross model) and the effect of the meal treatment is no longer significant. The coefficient of the bird count in the albatross model is similar to the coefficient derived in other warp strike modeling for this group using the same protocol (1.45, 95% c.i.: 1.38 – 1.96, Abraham et al. 2007). This suggests that this model is not over-fitting the data. The loss of significance of the treatment effect when bird count is included is consistent with the treatment primarily reducing the tori line strikes by reducing the numbers of birds around the vessel.

**Table 8 Summary of models of the tori line strike data, giving the coefficients of the fixed effects. The values give the median of the posterior distributions for each parameter, together with the 95% credible interval. The coefficients of the treatment effects have been exponentiated, so that they are multiplicative effects, with no effect having a value of one. Two models are shown, for each group, one with the bird counts included, and one without.**

		Fixed effects		
		Mealed	Minced	Log(bird count)
Albatross group	Treatment only	<b>0.14</b> (0.02 - 0.85)	0.3 (0.045 - 2.1)	-
	With bird count	1.1 (0.09 - 12)	0.37 (0.059 - 2.5)	<b>1.7</b> (0.27 – 3.5)
Other birds	Treatment only	0.69 (0.27 – 1.8)	0.34 (0.1 - 1.1)	-
	With bird count	0.77 (0.27 - 2.1)	0.5 (0.12 - 2.4)	0.98 (-0.83 – 2.9)

## 5. Discussion

The results from the experiment are clear: no significant effect of the mincing treatment was seen on any of the bird groups, with the exception of the feeding large albatross. The large albatross group comprises the *Diomedea* species (the royal and wandering albatross). They are only occasionally caught as bycatch by trawl vessels (Baird 2004a, 2004b, 2005) and attended the vessel in relatively low numbers (an average of 9 birds within the sweep area during the unprocessed treatment). Observations of birds around trawlers report that they are generally further from the stern than the smaller albatross (Petyt, 1995) and so may be less at risk from being caught on the warps. It seems that, while the result is statistically significant, it is unlikely to be of importance from a conservation point of view.

In contrast, mealing the offal, and so reducing the discharge to sump water, has a clear effect. This effect is especially strong for the small albatross group when they are feeding. This group is caught most frequently in trawl warps (Abraham et al, 2007), and so the reduction in the numbers of birds in this category is of potential importance.

During earlier warp strike work, no association was found between whether vessels running meal plants and a reduction in the rate of warp strikes (Abraham, 2005). Although meal plants were being used, it was not common practice at that time to meal much of the waste produced in the squid fishery, and so vessels that were running meal plants were still discharging offal. During this experiment however, the use of the meal plant eliminated all discharge apart from sump water.

From an operational point of view the experiment was successful. Aside from the initial problems with the pipe, the mincer worked well. One shortfall with the experiment was that relatively few tori line strike observations were made. Because of this, there are large uncertainties in the treatment effect on the tori line strikes. The treatment effect is just significant at the 95% confidence level for the meal treatment. Although there are few tori line strikes associated with the minced treatment, the modeling is unable to show that this is a significant effect.

## Acknowledgements

We are grateful to the vessel master, crew and onshore managers for their assistance with implementing the trial, and to Rick Guild of the Ministry of Fisheries observer programme for his many hours of work standing on the deck counting birds. We are also grateful to Chris Robertson of Wild Press for proposing mincing as a possible offal management strategy. This work was primarily the result of collaboration between Deepwater Group Ltd, the New Zealand Department of Conservation and Ministry of Fisheries. Much of the experimental logistics, and analyses and reporting, were funded through the Department of Conservation Marine Conservation Services Programme, by a levy on the quota holders of stocks primarily taken by trawling (project MIT2004/01). Observer placement was carried out by the Ministry of Fisheries.

## References

- Abraham, E. (2005). Warp strike observations. Final Research Report for Ministry of Fisheries project IPA2004-014. Ministry of Fisheries, Wellington.
- Abraham, E. R., Middleton, D. A. J., Waugh, S. M., Pierre, J. P., Walker, N., and C. Schröder (2007). A fleet scale experimental comparison of devices used for reducing the incidental capture of seabirds on trawl warps. In preparation for submission to *Can. J. Aq. Fish. Sci.*
- Baird, S. J. (2004a). *Incidental capture of seabird species in commercial fisheries in New Zealand waters, 2000-01*. New Zealand Fisheries Assessment Report 2004/58. Ministry of Fisheries, Wellington.
- Baird, S. J. (2004b). *Incidental capture of seabird species in commercial fisheries in New Zealand waters, 2001-02*. New Zealand Fisheries Assessment Report 2004/60. Ministry of Fisheries, Wellington.
- Baird, S. J. (2005). *Incidental capture of seabird species in commercial fisheries in New Zealand waters, 2002-03*. New Zealand Fisheries Assessment Report 2005/02. Ministry of Fisheries, Wellington.
- Heidelberger, P., and P. D. Welch. (1983). Simulation run length control in the presence of an initial transient. *Opns. Res.*, **31**, 1109-1144.
- Petyt, C. (1995). Behaviour of seabirds around fishing trawlers in New Zealand subantarctic waters. *Notornis*, **42**, 99-115.
- Plummer, M., Best, N., Cowles, K. and K. Vines (2006) CODA: Convergence diagnostics and output analysis for MCMC. *R News*, **6**, 7-11.
- R Development Core Team. (2007). *R: A language and environment for statistical computing*. R Foundation for Statistical Computing, Vienna.
- Thomas, A., O'Hara, B., Ligges, U., and S. Sturtz. (2006). Making BUGS Open. *R News*, **6**, 12-17.
- Venables, W. N. and Ripley, B. D. (2002). *Modern Applied Statistics with S* (4<sup>th</sup> edition). Springer-Verlag, New York.

## Appendix A: Observation comments

Extensive comments were made on the observation forms. All comments that were written on the forms are given verbatim below. The comments are grouped by treatment type, and are listed with the form number and the date.

### Unprocessed treatment

1 (18/09/2006). Vessel not fishing. Bird numbers high and aggressively feeding. More birds aft of 40m sitting in groups due to calmish conditions (usually more on the wing when windy).

2 (18/09/2006). Offal being discharged is nearly continuous. A break of 30 - 40 seconds before another lot comes out. There is no hose on DIS chute on to DIS conveyor. Therefore offal may back up a bit before releasing itself onto DIS conveyor. Also machines stop / starting during processing.

3 (18/09/2006). Less feeding activity than previous OBS. Numerous birds resting aft of sweep area.

5 (18/09/2006). No offal DIS during sweeps. Cape pigeons feeding from meal slick water portside.

7 (18/09/2006). Still many birds aft of sweep range sitting on water conserving energy in light winds.

8 (18/09/2006). Continuous DIS of offal these OBS. Numerous birds on the wing and sitting beyond sweep range.

9 (18/09/2006). Still very calm conditions. Many birds sitting / flying beyond sweep region.

12 (18/09/2006). Total meal discharged for OBS period today 12500kg.

48 (24/09/2006). Gear recently shot. Small amount of fish in factory. Few hoki, therefore not much offal to attract birds. Factory processing bycatch before putting HOK through Baaders.

49 (24/09/2006). Bird numbers on the increase as offal begins to flow from DIS chute.

50 (24/09/2006). All offal being discharged this tow, including whole fish discards.

52 (24/09/2006). Most birds on wing waiting for offal and whole fish to appear at STBD side.

54 (24/09/2006). Just as many birds beyond 40m mark.

62 (26/09/2006). Using a percentage for birds feeding. When condensed like this its hard to tell who is feeding or not. Approx 30-50 birds feeding at DIS chute at STBD side of vessel out of sweep area.

63 (26/09/2006). Offal not discarded during sweep. Birds feeding on sump discharge. Due to vessels slow speed large number of birds hanging around DIS outlet.

64 (26/09/2006). Offal not discharging when sweep carried out. Offal discharging off and on. Large numbers of birds flying outside sweep area.

65 (26/09/2006). Birds mainly on wing waiting for discharging which is still off and on. No discharge of offal during sweep.

67 (26/09/2006). Offal intermittently discharging. Factory processing a lot of SWA. At times SWA heads being DIS. HOK Baaders only running intermittently.

68 (26/09/2006). Continuous offal flow bringing wave after wave of all size birds feeding. A good example with a cross wind of 20kts.

70 (26/09/2006). Wind decreasing to 10kts. Variable. Birds still coming close to stern feeding on continuous supply of HOK offal. No real aggressive feeding.

71 (26/09/2006). Small albys staying away from warp/tori line area. Continuous flow of HOK heads & frames. Not attracting birds in close. Feeding by small albys carried out beyond tori's windbuoys. Basically same result as with minced offal.

72 (26/09/2006). All feeding activity from small albys is being done beyond windy buoys of toris. Benign weather conditions.

99 (30/09/2006). Bird numbers low - benign conditions again. Large groups of big birds sitting on water beyond sweep area. Small birds outnumber big birds on STBD side to the right of tori line feeding on offal. No real aggressive feeding. Majority of birds feeding from sitting on water. Very few birds dropping in from air to feed.

100 (30/09/2006). Vessel discharging SWA heads along with HOK offal when Baaders do a run.

101 (30/09/2006). Heads only coming through this sweep. Aggressive feeding from large albys taking advantage of small albys trying to swallow SWA heads. Total numbers of small albys still not high in sweep area. Large groups sitting on water beyond sweep area.

102 (30/09/2006). No change in conditions or activity.

104 (30/09/2006). Still benign conditions. Many birds sitting beyond sweep area.

105 (30/09/2006). HOK offal discharged this sweep. Most feeding carried out just behind stern.

106 (30/09/2006). No unprocessed offal discharged during sweep. Bird numbers low.

107 (30/09/2006). Numbers have increased due to HOK offal continuous discharge.



111 (03/10/2006). Fishing now in area 5 (SOU). 1st tow for this area. Factory empty no water on so sumps not working. Benign day for down here. Approx 60 - 80 birds sitting in a group beyond sweep area.

112 (03/10/2006). Predominant small alby here in Area 5 is whitecapped. WWA and LIN heads being DIS constantly. Guts and frames occasionally.

113 (03/10/2006). Different approach to feeding area due to head wind.

114 (03/10/2006). Bird numbers increasing beyond sweep area. Wind strengthening.

122 (05/10/2006). Vessel steaming to check out fishing spot. Factory processing LIN only at present. Only occasional offal being discharged.

123 (05/10/2006). No discharge of offal during sweep.

124 (05/10/2006). LIN heads and offal only discharged.

125 (05/10/2006). Continuous LIN and WWA heads and offal discharged this sweep.

126 (05/10/2006). Offal not long appearing again as DIS belt was inadvertently turned off. Bird numbers building.

149 (09/10/2006). No feeding close to warps. Birds landing to feed approx 5 - 10m from warp entry into water.

151 (09/10/2006). STBD tori blown way over to port side leaving STBD warp exposed.

153 (09/10/2006). STBD tori blown to the right opening up area around STBD warp. Feeding by white chins and small albys here.

### **Minced treatment**

24 (20/09/2006). First day with minced offal. Unfortunately, it's not doing what it was intended. We have a constant stream of minced offal coming from outlet surfacing in warp area. Aggressive feeding OBS from small albys. Little to no wind, therefore birds sitting on water forming large stream for some 200m behind vessel. Not sure if pipe is still attached. We will check this out soon. Offal is appearing at surface where pipe enters water indicating pipe may have broken off. Will check for pipe in zodiac at lunchtime.

25 (20/09/2006). Numerous birds feeding in area where warp would be if gear in water.

26 (20/09/2006). Little - no wind. Birds forming long stream behind vessel. Aggressive feeding from stern - 20m out by capeys and small albys. Birds settle down past that.

27 (20/09/2006). Checked pipe in Z boat - pipe has broken off. These OBS due to vessels speed the capeys and small albys are entering feedzone a good 10m from stern of vessel. More feeding done near 40m mark. All previous OBS today vessel has been traveling at trawling speed of 4kts.

28 (20/09/2006). Minced offal very visible. Small albys keeping away from warp zone despite offal visible.

29 (20/09/2006). Birds all sizes feeding away on minced offal right up to stern.

30 (20/09/2006). There is good size chunks of roe being discharged through the mincer. I am picking they are being forced through the plate holes, where they are quite pliable and they still stick together. Checked offal size at stern. Appears to be chunks of offal sticking together. Picking it is a bit of a build up in the pipe. Videod some footage it. Total meal produced for OBS period 17200 kg.

164 (23/09/2006). Offal outlet through wave gate and appearing through prop wash. Bird numbers slightly lower overall due to Rehua directly behind us. Offal appearing in good size lumps at times due to binding up in pipe. This attracting small albys right to stern of vessel.

165 (23/09/2006). Very benign conditions weather wise, calm sea and light breeze. Offal still appearing in prop wash in sizeable lumps. When birds bite into it the offal disperses very easily.

40 (23/09/2006). Numbers and activity similar to earlier OBS.

41 (23/09/2006). With more thrust while towing. The extra power is breaking up the mince into small pieces. The area (rectangle) from stern to end of toris is small alby free. Only a handful of capeys entering the area. Numerous birds sitting on water beyond sweep range. Very effective mitigation in these calm conditions.

42 (23/09/2006). Bird numbers significantly lower these OBS. Rehua close by. Offal appearing in clusters in slow prop wash.

43 (23/09/2006). Bird numbers have increased slightly due to Rehua recently sailing by.

44 (23/09/2006). Machines in factory not being used as no offal appearing at stern during this sweep.

45 (23/09/2006). Steady stream of minced offal being churned up by prop wash. Small albys staying well clear of warp area.

55 (25/09/2006). Vessel steaming. No HOK in factory. Bycatch being processed and offal going through mincer. However, because large prop wash at this speed I can't see any. Some feeding approx 25m aft in middle so could be mince appearing that far out.

56 (25/09/2006). Only bycatch offal appearing in very small amounts. Size is fingernail size.

57 (25/09/2006). Offal discharging in small pieces. Not binding up yet. All birds feeding close to stern back to edge of sweep area.

58 (25/09/2006). Offal still coming out in small pieces. No binding up into clumps.

59 (25/09/2006). Area around warp area is bird free. Minced offal is surfacing from stern ramp area to past warp entry points in wash system. Working extremely well. See video footage.

60 (25/09/2006). Birds keeping well away from offal until it reaches wind buoys of tori line. Bird #'s high. During warp strike OBS the minced offal ceased to be discharged so rotational hopper in factory could be cleared. Bird numbers dropped off considerably.

61 (25/09/2006). Gear half in water. Doors still up. Offal now starting to bind up. Problem with gear on deck.

83 (28/09/2006). Offal appearing in prop wash at stern. Attracting large birds. Long stream of birds forming from stern directly behind for 50 - 60m.

84 (28/09/2006). Offal appearing in small pieces approx fingernail size. Not binding up.

86 (28/09/2006). Just completed an experiment with tori lines. Birds are feeding on minced offal right up to stern. Put tori lines out for 5 min and birds stayed away from stern. Toris just taken in and count this sweep birds back up to stern. Numbers of small albys overall not high. Estimate all around including past sweep area = 200.

87 (28/09/2006). Birds flying and sitting on water past sweep area. Prop thrust pushing offal at speed past warp area. Birds flying over tori lines from a height checking out offal. Some landing in rectangle box. This due to cross wind. None landing near warps though.

88 (28/09/2006). Bird numbers fewer than when hauling tow 33 half an hour ago. Wind has eased. 1550h Sooty shearwaters have turned up in more numbers.

89 (28/09/2006). Count not that accurate as sun in my eyes. Most feeding carried out behind tori lines.

115 (04/10/2006). Clear, calmish conditions. Minced offal made up of LIN and WWA heads and guts. This attracting giant petrels and small albys. Smaller birds sitting on water from 10 - 15m back from stern and beyond.

117 (04/10/2006). Majority of birds sitting on water beyond sweep area. Area from stern to tori windybuoys clear of birds. Minced offal shunted to windybuoys and past by prop wash.

118 (04/10/2006). 95% of feeding carried out beyond tori's windybuoys. Minced offal very visible.

119 (04/10/2006). Long stream of birds sitting on water up to 300m astern. Most feeding carried out from just inside windybuoys and beyond. No activity around warps. Only time birds come closer to stern is when sumps discharge.

120 (04/10/2006). Since haul, majority of small albys not interested in minced offal. Beyond sweep area large groups sitting on water. Minced offal in less volume could be reason.

137 (07/10/2006). Vessel steaming to fishing ground. At this speed albys predominant species coming in waves, feeding on mince, landing 20 - 30m astern.

138 (07/10/2006). Notice how with this side wind STBD tori is blown towards centre leaving STBD warp unprotected. With mince discharging at centre it keeps birds away from STBD warp in contrast if offal coming out of normal discharge chute.

139 (07/10/2006). Wind has increased to 30 kts. Birds hovering over rectangle area dropping down to feed on mince. No real activity around warps by big birds. Birds sitting on water for short periods before doing circle back over feeding area.

141 (07/10/2006). Windy conditions. Prop wash is surging further back taking minced offal with it.

154 (10/10/2006). Vessel dodging in 50kt winds. Birds mostly on the wing trying to keep up with vessel in rough sea.

156 (10/10/2006). Small albys are spread out beyond sweep. Appear to have given up feeding on minced offal in these conditions (50kts) making room for small birds.

157 (10/10/2006). Small albys numbering 30 birds hovering each side of vessel keeping an eye on sump DIS.

160 (10/10/2006). Vessel steaming with weather behind us. Propwash surging offal 20m and beyond. More small albys obviously seeing it from air. However, small birds appear to be feeding more.

161 (10/10/2006). Small bird numbers very high with more on wing outside sweep range. Birds feeding on offal outside sweep range.

162 (10/10/2006). Small birds and a few big birds seem to feed when offal is visible as waves crest and in light blue water. Offal isn't visible from OBS position on fantail. Wind has eased to 20kts however sea still rough.

## **Mealed treatment**

13 (19/09/2006). Birds pecking at bits and pieces from sump discharge. Very small morsels and very quickly pass the danger zone. Small, albys, giant petrels and cape pigeons in groups of 100 follow discharge out way past sweep zone by sitting on water. No aggressive feeding.

14 (19/09/2006). Notice the groups of birds forming everytime the sump spurts out. This water contains bits of deck wash, however nothing substantial offal wise. It's all the birds have got. So is keeping them interested. Sumps activate when water level in factory reaches certain height.

15 (19/09/2006). Meal plant is now in full production and slick water being discharged from port side. No DIS from STBD side this sweep. Due to slight list.

16 (19/09/2006). Sumps working PT & STBD sides these sweeps.

17 (19/09/2006). Now wind has risen to 30 KTS more birds on the wing. Both sumps (STBD & Port) activated.

18 (19/09/2006). Vessel has changed course since last OBS. STBD sumps not activated this sweep of OBS due to slight list. Birds honing in on every discharge made from port sump and meal slick discharge picking out small morsels. Depending on wind direction dictates their proximity to warp area.

19 (19/09/2006). Both PT & STBD sumps activating intermittently. Dictating which side birds land on to look for food.

20 (19/09/2006). Bird numbers low this set of OBS. Many birds flying and sitting beyond range of sweeps. Wind has virtually died off. Flight patterns are scattered.

21 (19/09/2006). Only PT side sump activated during sweeps. Similar OBS & conditions to previous ones so far today.

22 (19/09/2006). Looks like we are steaming to CHCH to pick up parts for Baader machine. Factory still processing. Speed of vessel increased dramatically.

23 (19/09/2006). Vessel close to Banks Pen as going into Lyttleton. Birds predominantly on the wing to keep up with vessel. Bit of a melee every sump discharge. Not really typical fishing speed, however gives behaviour pattern outline of birds. Not likely to have gear in water again today. Total meal discharged for OBS period 20500 K. Have just noticed portside camera is starting to get soot from meal smoke. Will get it cleaned.

31 (21/09/2006). Sumps from portside activated during sweeps. This mainly attracts capeys with their number consistent with all other discards. Giant petrels feed on this discharge as well, with small albys in vicinity checking if any sizeable bits appear. Their numbers considerably lower however in this wind. They are on the wing beyond sweep range.

32 (21/09/2006). G-petrels and capeys feeding on meal slick water. Small albys on wing overseeing discharges for anything sizeable. 40% of landing and feeding activity happening at sump outlets by capeys and small albys.

33 (21/09/2006). Feeding activity predominantly capeys. Small albys on wing. Large groups out of sweep range. Definite reduction in small albys when gear in water. Albys decreased gradually in numbers around vessel the longer tow went on.

34 (21/09/2006). OBS carried out not long after haul of bag. Wind has eased with numerous birds back to sitting on water. STBD sump activated once during sweep. Meal sump intermittently going STBD side.

35 (21/09/2006). Small albys and capeys attracted close to vessel from STBD factory sump. Numbers significantly lower than when offal and mince discharged. Usually when

this protocol is carried out small albys would check out other vessels. However, they are hanging around due to this vessel only one fishing in area.

36 (21/09/2006). Vessel searching for fish marks at 6 kts. Port factory sump and PT meal sump attracting birds. Small alby numbers in sweep area consistent with no offal discarded.

37 (21/09/2006). Small alby numbers low. Can see large groups flying STBD and port sides 500m away.

163 (21/09/2006). Gear in water tori lines out. Small alby numbers very low.

73 (27/09/2006). All size birds feeding on small pieces from sumps and meal stickwater. Low numbers of birds in sweep area and beyond.

75 (27/09/2006). Big birds keeping out of tori area and stern.

78 (27/09/2006). Bird numbers very low. Apart from capeys.

81 (27/09/2006). Back to normal when only sump water being discharged. Bird numbers low in sweep area.

82 (27/09/2006). Capeys feeding on pieces in meal stickwater.

90 (29/09/2006). Benign conditions again. No wind, calm sea. Intermittent discharge of meal stickwater and port side sump. Mainly birds sitting on water in large groups in sweep area and beyond.

91 (29/09/2006). No change in conditions or activity.

92 (29/09/2006). No change.

93 (29/09/2006). No change in conditions or activity.

94 (29/09/2006). Gear not long in - vessel slowing down to towing speed. Very few small albys during sweep. Still benign conditions.

95 (29/09/2006). Birds coming in waves and only settle close to vessel when sump discharges.

96 (29/09/2006). Similar conditions and activity from birds as in previous OBS set for this tow.

97 (29/09/2006). Tow 37 not long shot. Small alby numbers have dispersed from haul of tow 36. Still clear calm conditions.

98 (29/09/2006). No change in conditions and activity.

108 (01/10/2006). Benign conditions again. Majority of birds sitting on water. Birds clear of rectangle area. Behind stern.

109 (01/10/2006). Gear not long shot. Still calm conditions. Large bird numbers spread out past sweep area.

129 (06/10/2006). Vessels has moved up to Area 5 leaving 3 other vessels back in Area 6. Bird numbers low due to no offal.

130 (06/10/2006). No sump discharges during sweep.

133 (06/10/2006). Large birds scattered in groups either flying or sitting beyond sweep area.

134 (06/10/2006). Notice how when gear is out of water the bird numbers increase closer to stern.

144 (08/10/2006). Vessel has hoved to as factory has plenty of fish. NW 25kts. Bird num [end of comment]

## Appendix B: OpenBugs code

An example of the OpenBugs code used to specify a Bayesian model for the bird count data. Initial values of the parameters `b_mu`, `b_minced`, `b_mealed`, `b_fishing`, `b_hours`, `b_wind_spd`, `logtheta` and `b_group` are supplied. The data is supplied as the variables `count` (the bird counts), `minced` (indicating minced treatment), `mealed` (indicating minced treatment), `fishing` (indicating minced treatment), `hours`, `wind_spd`, `N` (the number of observations), `M` (the number of random effects groups) and `group` (the random effects group of each observation).

```
model
{
  for( i in 1 : N ) {
    count[i] ~ dpois(mustar[i])
    mustar[i] <- r[i]*exp(mu[i])
    r[i] ~ dgamma(b_theta, rate[group[i]])
    mu[i] <- b_minced * minced[i]
    + b_mealed* mealed[i]
    + b_fishing* fishing[i]
    + b_hours*hours[i]
    + b_wind_spd*wind_spd[i]
  }
  for (j in 1:M){
    re[j] ~ dnorm(b_mu, tau_group)
    rate[j] <- b_theta/exp(re[j])
  }
  b_mu ~ dunif(-10,10)
  b_minced ~ dunif(-10,10)
  b_mealed ~ dunif(-10, 10)
  b_fishing ~ dunif(-10,10)
  b_hours ~ dunif(-10,10)
  b_wind_spd ~ dunif(-10,10)
  b_theta <- exp(logtheta)
  logtheta ~ dunif(-3, 5)
  b_group ~ dunif(0, 5)
  tau_group <- (1.0/(b_group*b_group))
}
```



## Appendix B: Seabird observation protocol

11 September 2006

### Purpose

This protocol aims to standardise the collection of seabird number and activity observations by observers as a proxy for seabird interactions with trawl gear.

### Area observed

Seabirds are to be observed in a semi-circular area of radius 40m, centred on the midpoint of the stern (Figure 15).

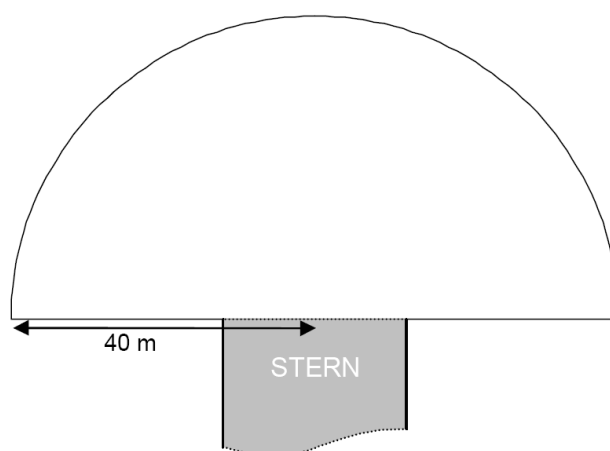

Figure 15 Area to be observed astern of vessel.

### Observation procedure

Each seabird count recorded should be the result of a single visual sweep through the observation area. That is, the observer should start at one side of the observation area and sweep their gaze across to the other side to yield a single sweep count. During each sweep the observer should estimate the number of seabirds in one of the categories defined below. Clearly the more birds present, the longer a sweep count will take. Each sweep must therefore be restricted to a maximum of one minute. (Analyses of these data will take account of the fact that larger numbers of birds present will result in lower precision estimates.) Ideally the maximum count period should be indicated by a countdown timer that is reset to one minute at the start of each sweep.

### Seabird and activity categories

Each observation set consists of fifteen sweep counts. For each of five groups of seabirds (Table 1) the number of birds in each of three activity classifications (Table 2) should be estimated. Counts must represent the number of birds engaged in that activity at the time of the sweep. Because counts are carried out sequentially, and a bird may have changed its activity between sweeps, this may mean that a bird is counted on more than one sweep count.

**Table 9.** Seabird categories to be used in seabird sweep count observations. Note that the cape pigeons are counted separately from the other small birds.

<i>Seabird group</i>	<i>Definition</i>
Large albatrosses	Royal and wandering albatrosses
Small albatrosses	Mollymawks, including all shy albatrosses (White-capped, Chathams and Salvins), yellow-nosed, black-browed, grey-headed and Buller's. Also any sooty albatrosses.
Giant petrels	Northern and southern giant petrels
Shearwaters	Shearwaters, petrels (except giant petrels and Cape pigeons), prions
Cape pigeons	<i>Daption capense</i>

**Table 10.** Seabird activity classifications to be used in seabird sweep count observations.

<i>Activity</i>	<i>Definition</i>
Flying	Flying or gliding
Sitting	Sitting on the water, but not feeding
Feeding	Feeding, or other feeding related activity including diving/surfacing, aggressive interactions with other birds, etc.

### Completing the form

1. All fields on the form must be completed for each observation period. For zero counts enter "0" – do not leave the field blank. The only field that might not be filled in is the tow number, if the vessel was not towing. In this case draw a line through the field.
2. Complete the form in the following sequence:
  - a. Circle the offal treatment in operation on this day of the trial
  - b. Record trip number, tow number (if towing) and vessel speed. You should note the vessel speed as you notify the bridge that you are commencing observations on deck.
  - c. Record the date and time of this observation.
  - d. Record the rate at which different types of offal are entering the observation area. Ensure you record what you observe, irrespective of the intended offal treatment. Record this before you start the seabird counts.
  - e. Use the diagram provided to illustrate approximately where in the observation area the different types of offal are present. Use "+" symbols to illustrate where the warps enter the water (if the vessel is fishing).
  - f. For each of the seabird species group/activity categories carry out a visual sweep of the observation area and record the number of birds in that category. Carry out the observations in the order indicated.
  - g. Add any additional observations in the Comments box at the bottom of the form.